

USER MANUAL

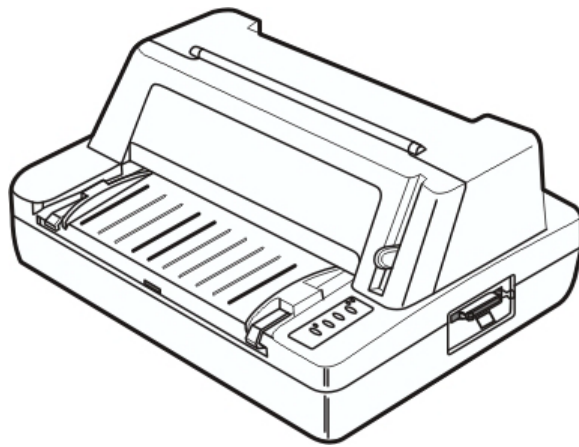

SEIKO Precision
FB – 380
Dot-Matrix Flatbed Printer

Important Safety Instructions

1. Read all of these instructions carefully and thoroughly and save them for later reference.
2. Follow all warnings and instructions in the manual as well as marked on the product.
3. Unplug this product from the power outlet before cleaning. Do not use liquid or aerosol cleaners. Use a damp cloth for cleaning.
4. Do not use this product near water.
5. Do not place this product on an unstable cart, stand or table. The product may fall, causing serious damage to you or the product.
6. Slots and openings on the cabinet and the back or bottom are provided for air ventilation. To ensure reliable operation of the product and to protect it from overheating, do not block or cover these openings. The openings should never be blocked by placing the product on a bed, sofa, rug or other similar surface. This product should never be placed near or over a radiator or heater. This product should not be placed in a built-in installation or kiosk stand unless proper ventilation is provided.
7. This product should be operated from the type of power source indicated on the rating label. If you are not sure of the type of power available, consult your local dealer or an electrician.
8. Depending on the country of shipment this product may be equipped with a 3-wire grounding-type plug, a plug having a third (grounding) pin. This plug will only fit into a grounding-type power outlet. This is a safety feature. If you are unable to insert the plug into the outlet, contact your local electrician to replace your obsolete outlet. Do not defeat the safety purpose of the grounding-type plug.
9. Do not allow anything to rest on the power cord. Do not locate this product in a location so that the power cord will be walked or driven over or on.
10. Never push objects of any kind into this product through cabinet slots as they may touch dangerous voltage points or short out parts that could result in a risk of fire or electric shock. Never spill liquid of any kind on the product.
11. Except as explained elsewhere in this manual, do not attempt to service this product yourself. Opening and removing those covers that are marked "Do Not Remove" may expose you to dangerous voltage points or other hazardous risks. Leave all servicing on those compartments to qualified service personnel.
12. The mains plug on this equipment must be used to disconnect the mains power.
13. Unplug this product from the power outlet and leave servicing to qualified service personnel under the following conditions:
 - A. When the power cord or plug is damaged or frayed.
 - B. If liquid has been spilled into the product.
 - C. If the product has been exposed to rain or water.
 - D. If the product does not operate normally when the operating instructions are followed. Adjust only those controls that are covered by the operating instructions since importer adjustment of other controls may result in damage and will often require extensive work by a qualified technician to restore the product to normal operation.
 - E. If the product has been dropped or the cabinet has been damaged.
 - F. If the product exhibits a distinct change in performance, indicating a need for service.

Note: The contents of this manual may be changed without prior notice.

Table of Contents

Chapter 1 Overview	1
Features	1
Chapter 2 Preparation	3
Unpacking	3
Parts Identification	4
Installation	5
<i>Installing the Front Table Extension Tray</i>	5
<i>Installing and Replacing the Ribbon Cassette</i>	5
Connecting the Interface Cable	7
Using the Parallel Interface and the USB Interface.....	7
Connecting to the Power Source	7
<i>Connecting the Power Cord</i>	7
<i>Turning the Power on and off</i>	8
Chapter 3 Loading Paper	9
Paper Thickness Adjustment	9
Loading Cut Sheets.....	10
Using Tractor Paper.....	11
Loading Tractor Paper.....	11
Tearing off Tractor Paper	13

Chapter 4 Printing from Your Software	14
Setting Up Your Printer To Work With Software	14
Chapter 5 Control Panel	15
Control Panel Keys and LEDs	15
Basic Control Panel Operations	16
Top of Form Adjustment Mode	16
Tear-off Adjustment Mode	17
Using the Setup Menu System.....	17
<i>To enter the Setup Menu System and change the settings</i>	18
<i>To exit the Setup Menu System</i>	18
<i>Printing the Current Setting Report</i>	18
<i>Options of the Setup Menu System</i>	21
Restoring Factory Printer Settings.....	23
Using the Self Test Functions	23
<i>Slide Pattern Printing Test</i>	23
<i>Maintenance Printing Test (H pattern)</i>	23
Hex Dump Mode	24
Appendix A	25
Maintenance and Fault Finding.....	25
Error LED on the Control Panel.....	27
Appendix B	28

Specifications	28
<i>General</i>	28
<i>Print Head</i>	28
<i>Mechanism</i>	29
<i>Paper</i>	29
<i>Print mode specifications</i>	30
<i>Graphic Print Specifications</i>	31
<i>Parallel Interface</i>	31
<i>USB Interface</i>	32
Command Code Summary	32
<i>Epson Emulation</i>	32
<i>Select Code Pages</i>	35

Chapter 1 Overview

Features

Thank you for purchasing this SEIKO Precision FB-380 printer.

Combining high speed, high quality output with advanced paper handling capabilities, this versatile, 24-pin, flatbed printer is ideal for a wide range of multi-part and cut-sheet printing requirements. Reliability, flexibility and ease-of-use are key features, making the FB-380 the perfect choice for performing demanding applications in a variety of environments.

Versatile, Reliable, Straight Paper Path

The straight paper path enables paper to feed through the printer without bending, thus reducing the risk of paper jamming. The versatile FB-380 prints on a wide variety of paper types from 7-part forms to labels, envelopes and reports, as well as media up to 0.45mm thick.

Easy Paper Handling

The printer has several other useful features, which help eliminate paper handling problems and ensure quick, accurate results.

Automatic paper loading/ejection with automatic skew detection

The automatic paper load function ensures cut sheet paper fed into the printer is correctly positioned. The FB-380 also has an automatic skew detection function, which ejects forms which are not fed in straight.

At the touch of a button, tractor paper loaded onto the tractor is automatically set to the printing position. When printing is completed, the paper feeds out to the front table for easy tear-off.

Zero tear-off function

This causes tractor paper to be automatically fed to the tear-off position at the edge of the window cover, for easy tear-off at the perforations after printing. This zero tear-off capability helps eliminate paper wastage.

Paper park function

A simple command on the control panel enables the tractor paper to be retracted (parked) outside of the print mechanism so that after switching the paper path select lever, cut sheet paper can be fed into the printer from the front.

After the cut sheet paper has been printed, reverse the paper path lever so that the fanfold stationery can be advanced back into the print mechanism for the next print job.

Automatic Interface Switching

The FB-380 is equipped with two interface connectors and therefore accepts both parallel (Centronics) and USB data transfer. The printer automatically detects the type of data transfer received from the host computer and switches to the corresponding interface type.

High Quality, High Speed Printing

This FB-380 produces high quality printing in Letter Quality mode at a speed of 83 CPS at 10 CPI. In Draft mode, the printer outputs 250 CPS at 10 CPI or 375 CPS at 15 CPI.

High Resolution Graphics

A maximum resolution of 360×360 DPI enables the printer to produce fine, sharp graphics.

User-Friendly Control Panel

Current print status and access to all printer function is available via simple commands from the control panel. In addition, the control panel is used to access the menu system (Setup Menu System) with complete control over the printer's set-up.

Emulation

The printer supports Epson ESC/P2 emulation as standard.

Bar Code Generator

NW-7, EAN-13, EAN-8, Code 39, Industrial 2 of 5, Interleaved 2 of 5, Code 128B, and Code 128C are built-in as standard.

Chapter 2 Preparation

Unpacking

Check each item against the following packing list, if any of these items are missing, please contact your dealer.

NOTE

Hold the bottom of printer in the box, and then carefully lift it up. As you unpack, save all the original packing materials. They are specially designed to protect the printer and will make later repacking easy, if necessary . Before using your new printer, please remove the shipping pads from the printer. Open the Window cover and remove the Styrofoam shipping pads.

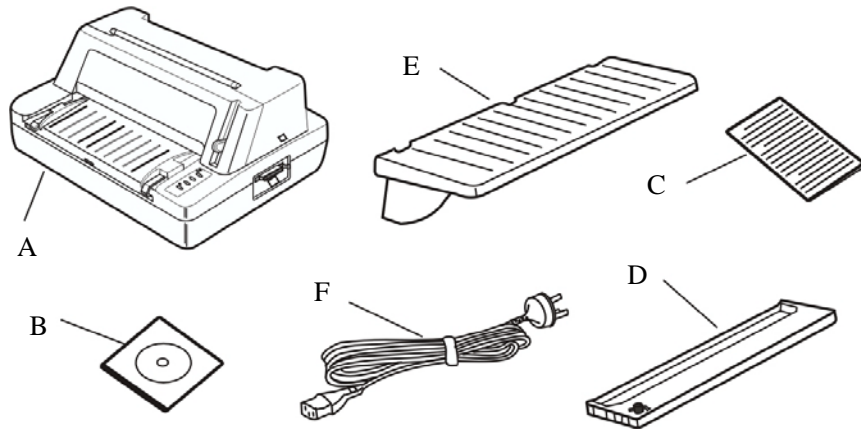

Figure 2-1 Packing list in the printer box

- A Printer
- B Driver CD and User's manual
- C Install guidebook
- D Ribbon cassette
- E Front table extension tray
- F Power cord

Parts Identification

Figures 2-2 and 2-3 highlight the main components of the printer.

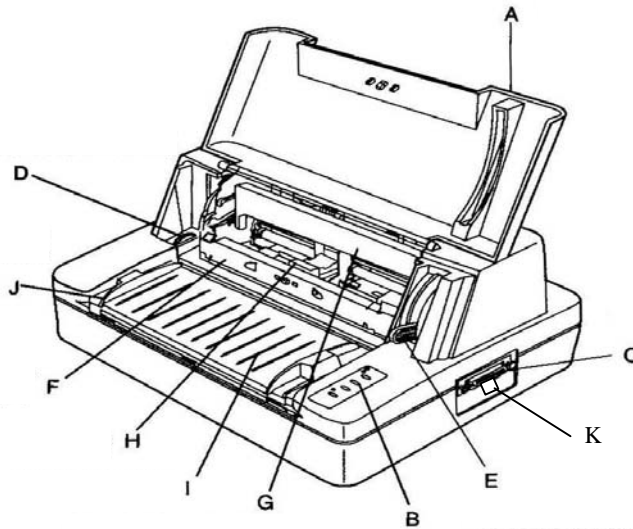

Figure 2-2 Main parts of printer (front view)

- | | | | |
|---|------------------------------|---|---------------------------|
| A | Window cover | G | Ribbon cassette cartridge |
| B | Control panel | H | Print head |
| C | Parallel interface connector | I | Front table |
| D | Paper feed knob | J | Cut sheet guide |
| E | Gap adjust lever | K | USB interface connector |
| F | Sub friction roller | | |

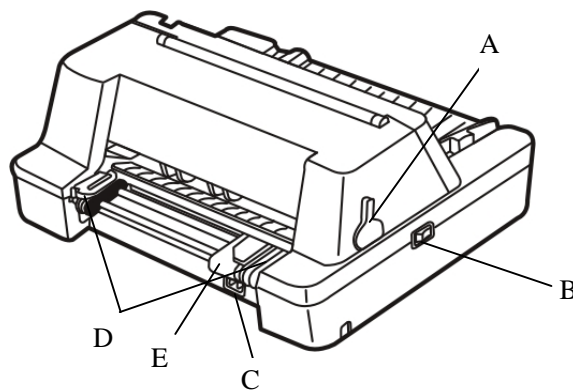

Figure 2-3 Main parts of printer (rear view)

- | | | | |
|---|--------------------|---|--------------------|
| A | Paper select lever | D | Tractor |
| B | Power switch | E | Paper guide pulley |
| C | Power supply inlet | | |

Installation

Before placing the printer in your chosen location, consider the following guidelines:

- This printer should be placed on a normal table or desk. Be sure that the surface is level, to avoid an uneven load on the carriage as it operates.
- Do not install the printer where it may be subjected to:
 - Where there is excessive dust.
 - Where it may be splattered with oil or metallic dust.
 - Where it may be exposed to direct sunlight.
 - Where it may be accidentally splashed with water.

Installing the Front Table Extension Tray

Simply attach it to the front of printer by locating the 3 support lugs in the 3 slots at the edge of the printer front feed.

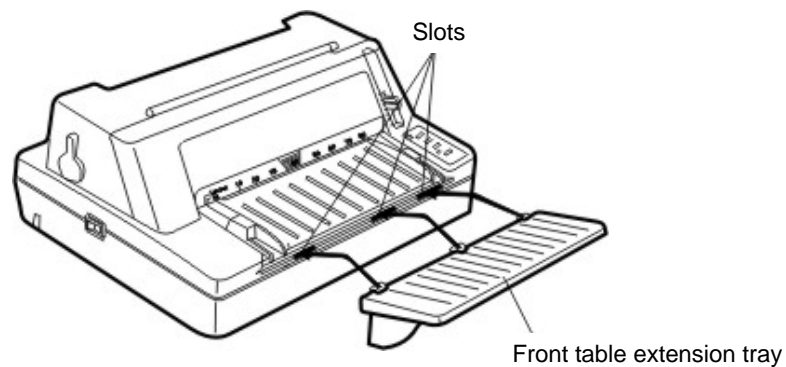

Figure 2-4 Installing the front table extension tray

Installing and Replacing the Ribbon Cassette

- 1 Ensure the printer is turned OFF.
- 2 Open the window cover by holding the side of window cover as shown in Figure 2-5.

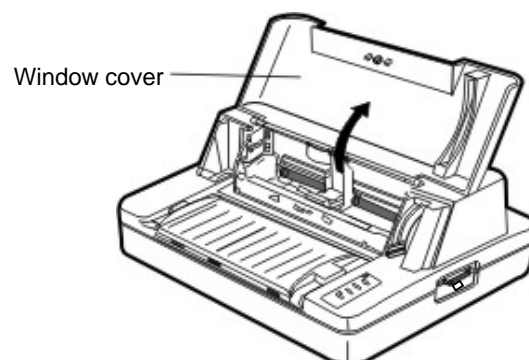

Figure 2-5 Opening the window cover

- 3 Pull the Sub friction roller unit by gripping the center area of the unit by your forefingers. Then lift it up until the unit is positioned on the top of printer as shown in Figure 2-6.

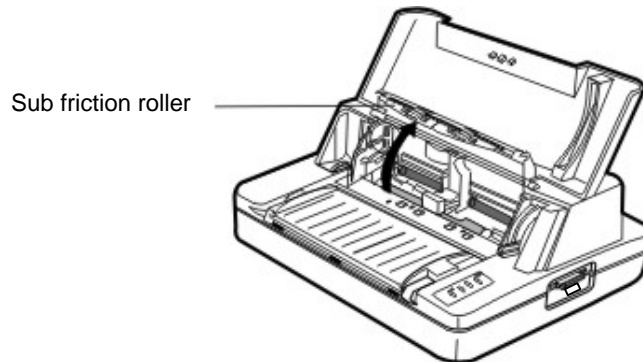

Figure 2-6 Opening the sub friction roller unit

- 4 If necessary, centre the print head by hand.
- 5 Hold the ribbon cartridge with the knob facing upwards and turn the ribbon knob in the direction shown by the arrow to take up any slack in the ribbon.
- 6 To install the ribbon cartridge, hold it with both hands, with the ribbon facing down as shown in Figure 2-7.

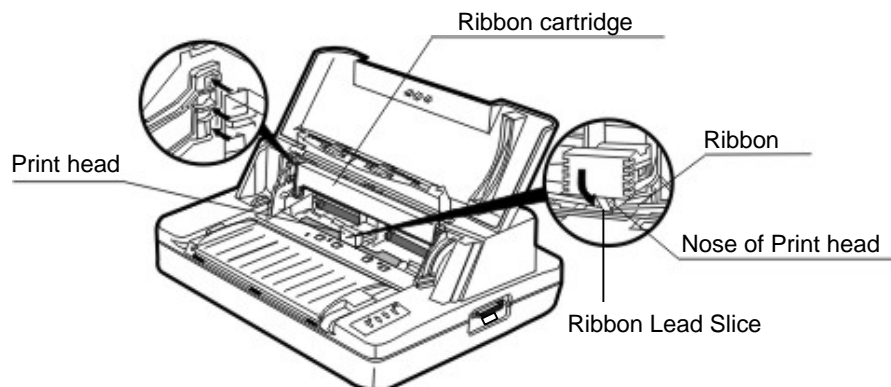

Figure 2-7 Installing the ribbon cassette

Make sure that the following:

- ❑ When you look at the print head you will find a small piece of black plastic on the thin metal sheet of the ribbon guide. Make sure that the ribbon goes under the piece of plastic.
 - ❑ Position the ribbon cartridge with the tabs on its case over the slots inside the printer case.
 - ❑ With the ribbon cartridge and ribbon correctly positioned, gently push the cartridge towards the back of printer until it clicks into place.
- 7 Move the print head from side a few times to make sure the ribbon goes into the ribbon guides.
 - 8 Having installed the ribbon, lower the sub friction roller and gently push it shut until you hear a click. Then close the window cover.

Connecting the Interface Cable

Connect the parallel or USB interface cable as shown in the figure 2-8 below:

Caution

Make sure that the power switches of both printer and host computer are turned OFF before you connect the parallel interface cable.

Using the Parallel Interface and the USB Interface

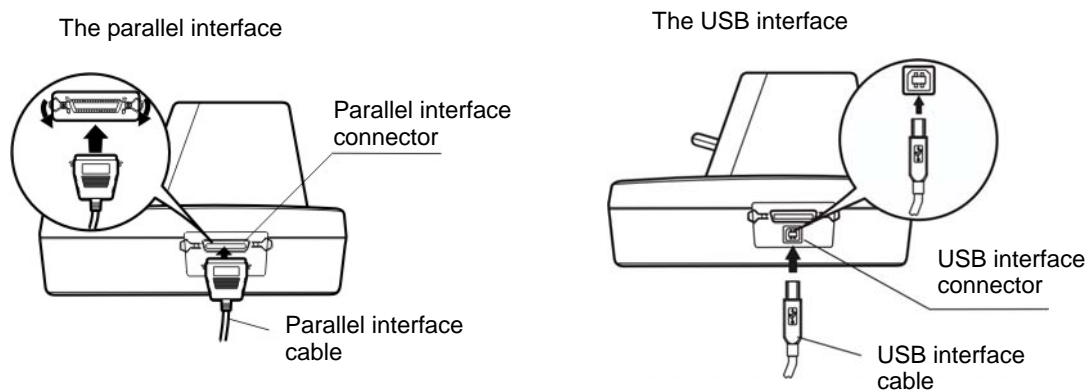

Figure 2-8 Connecting the parallel interface cable and the USB interface cable

Connecting to the Power Source

Connecting the Power Cord

Plug the power cord (supplied) into the power inlet at the rear of the printer.

Check that the power switch (located on the left of the printer) is in the OFF position, then plug the power cord into the wall outlet.

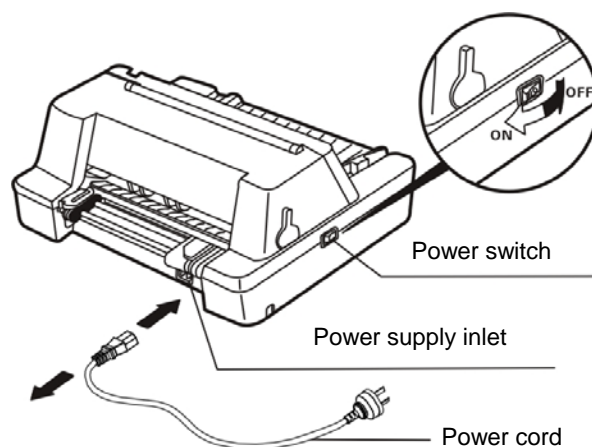

Figure 2-9 Connecting the power cord to the printer

Turning the Power on and off

To turn the printer ON, press the **I** mark on the power switch.

To turn the printer OFF, press the **O** mark on the power switch.

Chapter 3 Loading Paper

Paper Thickness Adjustment

Before loading cut sheet or tractor paper, you have to adjust the gap adjust lever on the right of the printer.

To feed thicker papers through the printer, you need to move the gap adjust lever from its standard position.

The lever moves the print head relative to the platen so that there is more room for the paper.

Adjusting the gap adjust lever

To obtain good quality printing and prevent problems (paper jam etc.) adjust the Gap adjust lever as shown in the Figure 3-1. The scale number # 1 shown in Figure 3-1 identifies the standard paper thickness setting. This is the recommended setting for most papers. Use Table 3-1 to find the recommended setting for other papers.

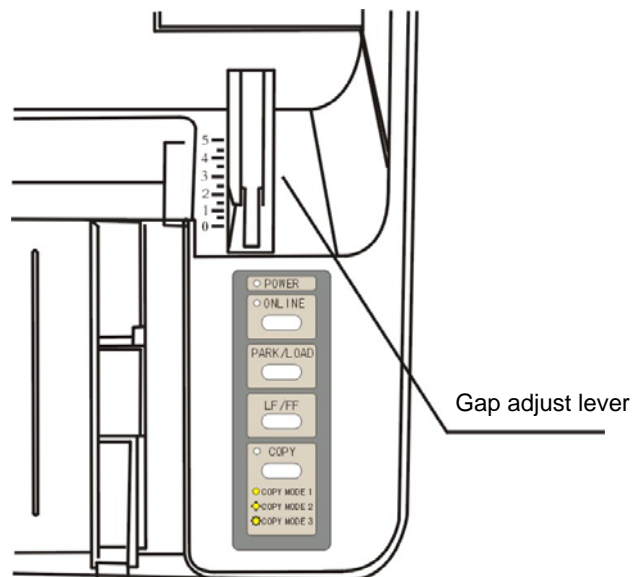

Figure 3-1 Setting the gap adjust lever

Position	Copies	Thickness
5	7	0.45mm
4	6	0.36mm
3	4 or 5	0.24 to 0.30mm
2	2 or 3	0.12 to 0.18mm
1	1	0.06mm

Table 3-1 Paper thickness setting

Loading Cut Sheets

- 1 Turn the printer on.
- 2 Set paper select lever toward the back of printer as shown in Figure 3-2.

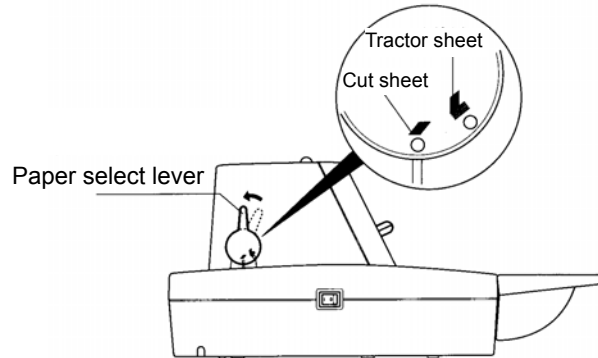

Figure 3-2 Setting the paper select lever

- 3 Position the left hand cut sheet guide by referring to the marking on the window cover. The positions for A4 and Letter size paper are indicated on the left side of the window cover as shown in Figure 3-3.

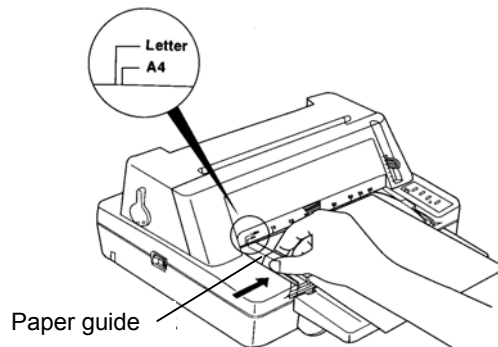

Figure 3-3 Adjusting the paper guide

- 4 Set the gap adjust lever for example to the position "1" for thin paper and then insert the paper as shown in Figure 3-4.
The paper is fed automatically into the printer and stops at the print start position. You can set the printer to detect skew so if the paper skews during loading, the printer detects it and automatically ejects the paper to the front table.

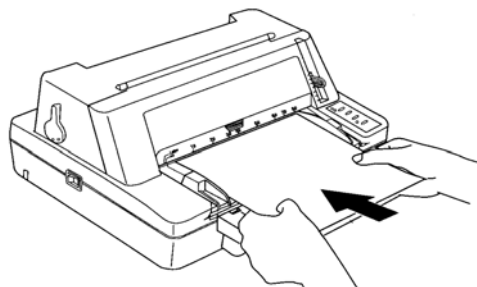

Figure 3-4 Loading cut sheet

- 5 After the above steps, the printer is ready to print.

NOTE

The printer's skew detection level can be set within the Setup Menu System. Be careful with the lowest possible setting because the printer might reject the paper due to even the smallest skew. If this happens, try a more medium setting.

Using Tractor Paper

This printer feeds tractor paper from the rear of the printer to the front.

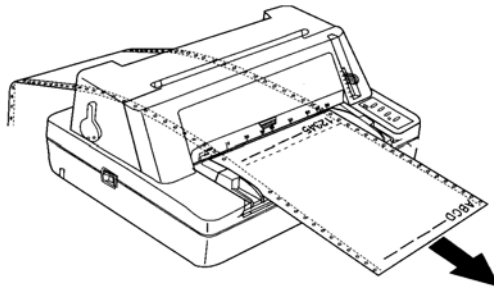

Figure 3-5 Feeding direction of tractor paper

Loading Tractor Paper

- 1 Turn the printer on.
- 2 Set paper select lever toward the front of printer as shown in Figure 3-6.

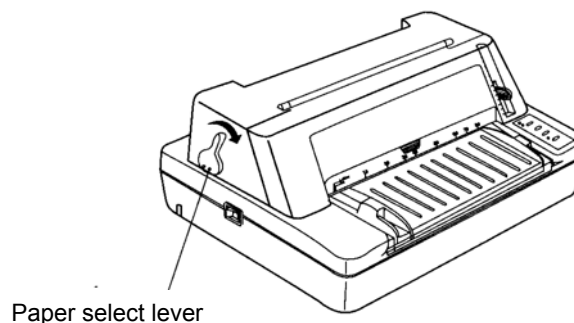

Figure 3-6 Setting the paper select lever

- 3 Release the lock lever of left tractor and move the tractor to the left edge of the paper path. Fasten the lock lever to lock the tractor in position.
- 4 Open the tractor paper guide and place the paper on the sprocket pins as shown in Figure 3-7, then close the paper guide. If you are using preprinted paper or labels, install them with the printed or labeled side facing upwards.

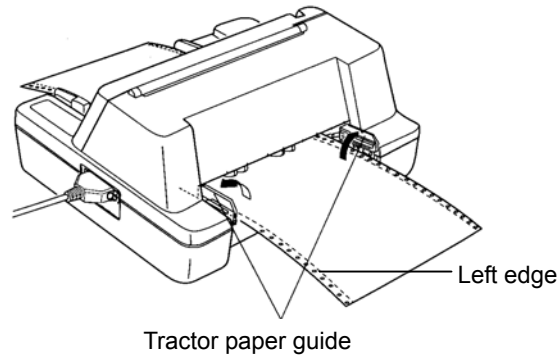

Figure 3-7 Setting tractor paper into the tractor

NOTE

When paper is loaded into the tractor, please set the top of paper to the edge of the tractor paper guide as shown in Figure 3-8.

- 5 Release the lock lever of the right tractor and open the tractor paper guide. Place the paper on the sprocket pins, then close the paper guide.

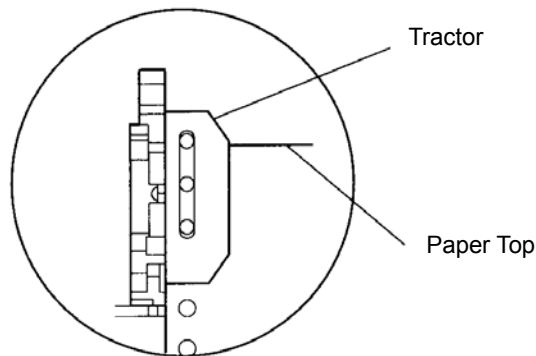

Figure 3-8 Setting paper on the sprocket pins

- 6 Slide the right tractor to left to take up any slack in the paper, and then fasten the lock lever to fix the tractor in position.

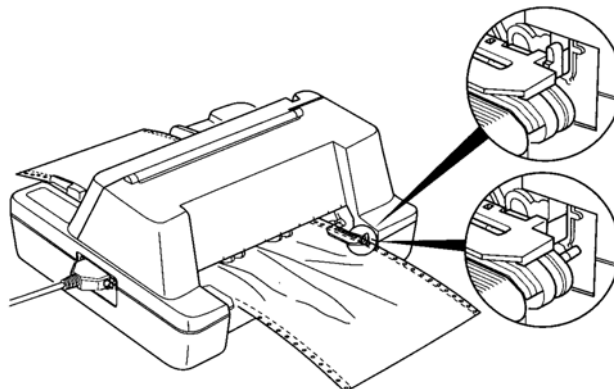

Figure 3-9 Adjusting the tractor position

- 7 Align the paper with the print start position.
Ensure the tractor paper is in line with the print start position. If the paper is not aligned with the print start position, release the tractor lock levers of the left and right tractors, align the paper, and then fasten the lock lever to lock the tractors.

Tearing off Tractor Paper

To tear off the paper, make sure that printed-paper is fed to the front table. If not, turn offline then press **PARK/LOAD** key.

Hold the edge of paper and pull it to the edge of the window cover as shown in Figure 3-10.

If the perforation of the paper is not at the edge of the window cover, adjust the tear-off position (refer to chapter 5, Control Panel)

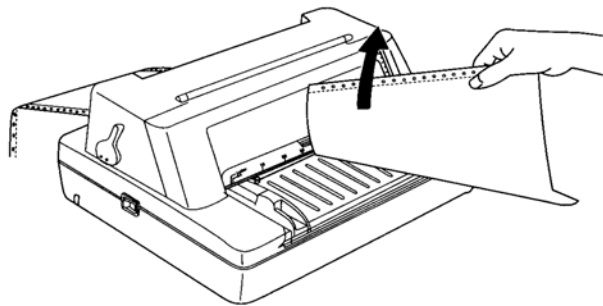

Figure 3-10 Tractor paper tear-off

Chapter 4 Printing from Your Software

Setting Up Your Printer To Work With Software

- The printer supports Epson ESC/P2 emulation.

You can select the Epson LQ-570+ driver for this printer, but the best way to ensure that all the features on your printer are supported by the software is to use the SEIKO Precision printer driver. If the driver is not available in your software package please call your software company. You may also check our web site for the suitable driver since we are updating the available drivers from time to time.

Your printer is supplied with a CD-Rom including the printer drivers for Microsoft Windows 98 and Windows 2000/XP. Please load the printer driver into your software according to the instructions on the driver CD.

Chapter 5 Control Panel

Control Panel Keys and LEDs

The control panel consists of four keys and three LEDs as shown in Figure 5-1

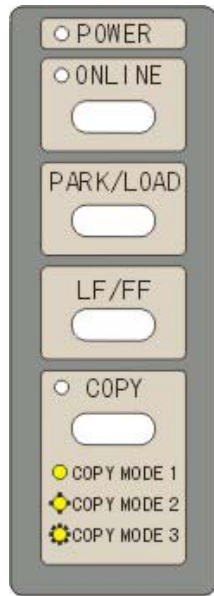

Figure 5-1 The printer control panel

The following table details each indicator LED function:

LED Indicator	On	Off
POWER (green)	Lights when the printer is turned on. It flashes when paper runs out and during error condition (See Appendix A)	The printer is turned off.
ONLINE (green)	Lights when the printer is online.	The printer is offline
COPY MODE (yellow)	Lights when the printer is in COPY MODE 1. Flashes slowly when the printer is in the COPY MODE 2. Flashes quickly when the printer is in the COPY MODE 3.	The printer is in the normal mode.

Table 5-1 LEDs on the control panel

NOTE

If you set the scale number of the lever position equal to or greater than 2 in the normal mode, the printer will transfer to the COPY MODE 1 as the current printing mode. However, the COPY MODE LED is still off.

Basic Control Panel Operations

You can use the four keys on the control panel to operate your printer.

- ONLINE** Pressing the **ONLINE** button, toggles between **ONLINE** and **OFFLINE** mode.
- PARK/LOAD** In the offline mode, pressing the **PARK/LOAD** button shortly controls feeding tractor paper or cut sheets
- LF/FF** In the offline mode, press the **LF/FF** key to feed the paper line by line. Alternatively, hold the key down for 2 seconds, the printer will eject the single sheet paper, or advance the tractor paper to the tear-off position. And if you press LF/FF key again the tractor paper will be reversely fed to the top-of-form position of the next page.
- COPY** In the offline mode, pressing the **COPY** key toggles among the four modes: **NORMAL**, **COPY MODE 1**, **COPY MODE 2** and **COPY MODE 3**.

To Change Speed Mode

In the offline mode, pressing the **PARK/LOAD** key for more than 2 seconds toggles between the **LETTER QUALITY** mode and **HIGH-SPEED** mode, with a beep sound for confirmation.

NOTE

The printer can only print DRAFT font in the HIGH-SPEED mode. If you need any other font listed in the SETUP MENU SYSTEM, please change to the LETTER QUALITY mode. Please note that push button selections do override menu settings.

Top of Form Adjustment Mode

The top of form setting determines the margin between the top of paper and the first printed line (the top margin).

In the **ONLINE** mode, press the **LF/FF** key for about 3 seconds to enter the top of form adjustment mode. The **ONLINE** and **POWER LED** will blink alternating.

NOTE

Your application software usually sets your top margin. You shouldn't need to change the top of form setting very often.

Use the **PARK/LOAD** and **LF/FF** keys to alter the top of form setting:

PARK/LOAD: Increase the top of form by 1/60 inch. You can increase the margin to a maximum of +60 increments (+60/60 inch) from the factory setting.

LF/FF: Decrease the top of form by 1/60 inch. You can decrease the margin to a maximum of -10 (-10/60 inch) from the default setting.

To exit and save your new setting, press the **ONLINE** button. The **POWER LED** and **ONLINE LED** blink simultaneously 3 times with a beep, then the **POWER LED** will be on.

NOTE

To exit without saving, just turn the printer OFF.

Tear-off Adjustment Mode

There is a tear-off bar at the edge of the window cover. When you have finished printing, you can advance the tractor paper on the tracker to the tear-off bar by the tear-off function to easily tear off the perforated sheets. The tear off setting determines the distance between the perforation of tractor paper and the tear-off bar. If the default distance is not suitable for you, you can adjust it by the printer's tear-off adjustment feature.

With the printer online, press both the **PARK/LOAD** and **LF/FF** keys for about 3 seconds to get the printer to enter the tear-off adjustment mode. When the printer enters this mode, the **ONLINE LED** and the **POWER LED** blink alternately.

Use the **PARK/LOAD** and **LF/FF** keys to alter the tear-off setting:

PARK/LOAD: Press the **PARK/LOAD** key to adjust the distance in 1/60 inch increments. You can maximum increase to +15/60 inch

LF/FF: Press the **LF/FF** key to adjust the distance in 1/60 inch decrements. You can maximum decrease to -15/60 inch

To exit and save your new setting, press **ONLINE** key. The **POWER LED** and the **ONLINE LED** blink simultaneously for 3 times, then the **POWER LED** turns on. Your new tear-off setting value is saved.

NOTE

To exit without saving, just turn off the printer.

Using the Setup Menu System

The factory settings of this printer are selected to meet the requirements of the majority of users. However, you may want to use a different character set for a different language or you may prefer printing in different font or style. To achieve this, you can use the Setup Menu System to create your own printer settings by modifying or changing the factory defaults.

The Setup Menu System is divided into several groups, and each group contains a number of menu lists, each list containing several settings. You can select a new setting of the menu list and save it, or just go to the next menu list without altering the current setting.

To enter the Setup Menu System and change the settings

1. Lift the window cover of the printer.
2. Eject any paper currently in the printer (or park tractor paper) then switch the printer online.
3. Keep pressing the **PARK/LOAD** key for 3 seconds.

This starts the Setup Menu System and prints the instructions for using it. The current setting is underlined.

The print head points to the current selection in the menu.

4. Make a selection from the menu with the keys on the control panel:

Press:	To:
PARK/LOAD	Move the print head to the next menu selection. Repeat this until you get the selection that you want.
LF/FF	Save the setting that is currently indicated by the print head position, and go to the next menu.
ONLINE	Move to the next menu without altering the current setting.
COPY	Go to the next menu group.

5. When you have made all of your settings (remember that you don't have to do go all the way through the menu system), switch the printer off and then turn on again.

Each time you switch the printer on, it uses the new saved settings. Keep the printout of the menu selections so that you know what the current settings are.

To exit the Setup Menu System

Turn the printer off, and then turn on again.

* New settings of the menu will be stored.

NOTE

1. You do not have to go all the way through the menu system. Once you have made all the changes you want, you only need to exit the Setup Menu System by switching off the printer. When you switch it on again, the printer uses the new settings.
2. When the compress mode is effective, the High Speed mode will not be valid.

Printing the Current Setting Report

You can use the information in the current report to decide which settings you want to change.

To print the current settings:

1. Turn the printer off.
2. Hold down both the **PARK/LOAD** and **LF/FF** keys
3. Turn the printer on.

The printer automatically loads paper and prints the current settings. An example print out is shown in Figure 5-2.

SEIKO Precision FB-380

Current Setting Report

Current settings are FILLED.

PRINT STYLE

FONT	<u>ROMAN</u>	SANS SER	COURIER	PRESTIGE	SCRIPT	OCR-B	OCR-A
PITCH	<u>10 CPI</u>	12 CPI	15 CPI	PROPORTIONAL			

PAGE LAYOUT

LINE SPACING	<u>6 LPI</u>	8 LPI					
FORM LENGTH	<u>5 INCH</u>	7 INCH	LETTER	<u>A4</u>	12 INCH	14 INCH	
PAGE SKIP	<u>OFF</u>	ON					
COMPRESS PRT	<u>NORMAL</u>	75%					

PRINT MODE

TEXT DIR	<u>BI-DIR</u>	UNI-DIR
GRAPHIC DIR	BI-DIR	<u>UNI-DIR</u>

CHARACTER

SLASH ZERO	<u>OFF</u>	ON
CHARACTER SET	ITALICS	<u>GRAPHICS</u>
INTL CHAR SET	<u>U.S.A.</u>	FRANCE GERMANY U.K. DENMARK1 SWEDEN ITALY
	SPAIN 1	JAPAN NORWAY DENMARK2 SPAN 2 LATIN AM KOREA
	LEGAL	
CODE PAGE	<u>U.S.A.</u>	MULTI PORTUGAL CANADA NORWAY EAST EURO CYRILLIC
	RUSSIAN	HUNGARY KAMENICKY TURKEY ICELAND BULGARIA MAZOVIA
	GRK 437	GRK 851 GRK8859-7 GRK 1253 ARAB NLS ARAB EXT WIN LATI
	WIN LAT2	ISO LTN1 ISO LTN2 TUR8859-9 ISO LTN9 KBL LATIN 7

INSTALL

QUIET MODE	<u>OFF</u>	ON
AUTO LF	<u>OFF</u>	ON
AUTO TEAR OFF	OFF	0.3 SEC. <u>0.5 SEC.</u> 1.0 SEC.
LOADING	PUSH KEY	0.5 SEC. <u>1.0 SEC.</u> 2.0 SEC.
SKEW DETECTION	<u>OFF</u>	ON
SKEW LEVEL	001	002 <u>003</u> 004 005 006 007
	008	009 010

Figure 5-2 Current Setting Report

Options of the Setup Menu System

The following printout in Figure 5-3 shows the selections from the Setup Menu System and is followed by a description of how to use it in Table 5-2 (Options of the Setup Menu System).

SEIKO Precision FB-380							
SETUP MENU SYSTEM							
Use the PARK/LOAD key to point the print head to the desired setting.							
Use the LF/FF key to store the new setting and go to the next menu.							
Use the ONLINE key to go to the next menu without storing a new setting.							
Use the COPY key to go to the next menu group.							
Current settings are <u>UNDERLINED</u> . New settings will be FILLED .							
PRINT STYLE							
FONT	<u>ROMAN</u>	SANS SER	COURIER	PRESTIGE	SCRIPT	OCR-B	OCR-A
PITCH	<u>10 CPI</u>	12 CPI	15 CPI	PROPORTIONAL			
PAGE LAYOUT							
LINE SPACING	<u>6 LPI</u>	8 LPI					
FORM LENGTH	<u>5 INCH</u>	7 INCH	LETTER	<u>A4</u>	12 INCH	14 INCH	
PAGE SKIP	<u>OFF</u>	ON					
COMPRESS PRT	<u>NORMAL</u>	75%					
PRINT MODE							
TEXT DIR	<u>BI-DIR</u>	UNI-DIR					
GRAPHIC DIR	<u>BI-DIR</u>	<u>UNI-DIR</u>					
CHARACTER							
SLASH ZERO	<u>OFF</u>	ON					
CHARACTER SET	<u>ITALICS</u>	<u>GRAPHICS</u>					
INTL CHAR SET	<u>U.S.A.</u>	FRANCE	GERMANY	U.K.	DENMARK1	SWEDEN	ITALY
	SPAIN 1	JAPAN	NORWAY	DENMARK2	SPAN 2	LATIN AM	KOREA
	LEGAL						
CODE PAGE	<u>U.S.A.</u>	MULTI	PORTUGAL	CANADA	NORWAY	EAST EURO	CYRILLIC
	RUSSIAN	HUNGARY	KAMENICKY	TURKEY	ICELAND	BULGARIA	MAZOVIA
	GRK 437	GRK 851	GRK8859-7	GRK 1253	ARAB NLS	ARAB EXT	WIN LAT1
	WIN LAT2	ISO LTN1	ISO LTN2	TUR8859-9	ISO LTN9	KBL	LATIN 7
INSTALL							
QUIET MODE	<u>OFF</u>	ON					
AUTO LF	<u>OFF</u>	ON					
AUTO TEAR OFF	OFF	0.3 SEC.	<u>0.5 SEC.</u>	1.0 SEC.			
LOADING	PUSH KEY	0.5 SEC.	<u>1.0 SEC.</u>	2.0 SEC.			
SKEW DETECTION	<u>OFF</u>	ON					
SKEW LEVEL	001	002	<u>003</u>	004	005	006	007
	008	009	010				
To activate the newly stored settings, please turn on the power again.							

Figure 5-3 Setup Menu System

Options	Description
FONT	Set the font for the printer to use in the absence of any font control instructions from your software.
PITCH	Set the pitch to determine the horizontal spacing of the printed characters.
LINE SPACING	Set the vertical spacing of the printed characters. You can set it to either 6 LPI (the default setting) or 8 LPI.
FORM LENGTH	Set the length of your printer paper, for both cut sheets and continuous-feed paper.
PAGE SKIP	Select (ON) or cancel (OFF, the default) a bottom margin of one inch.
COMPRESS PRT	Select compressed print mode or normal print mode.
TEXT DIR	Set unidirectional or bi-directional printing for text. Bi-directional (the default) is faster because the print head prints in both directions. Unidirectional is slower but produces better printing quality.
GRAPHIC DIR	Set unidirectional or bi-directional printing for graphics. It is set to UNI-DIR by default for better quality.
SLASH ZERO	Select or cancel the printing of a slash (/) through zero to distinguish them from the letter O.
CHARACTER SET	Select character set into Italic Character Table or Graphic Character Table.
INTL CHAR SET	Select among international character sets.
CODE PAGE	Select a code page
QUIET MODE	Select the printer into quiet mode. The acoustic noise is lower but the printing speed is reduced by half.
AUTO LF	Select (ON) or cancel (OFF) the automatic advance of the paper by one line after every carriage return command.
AUTO TEAR OFF	Enable or disable AUTO TEAR OFF function. The feed delay for the tear-off advance can be set.
LOADING	This determines the action of the printer while the single sheet paper is front feeding. PUSH KEY disables automatic loading allowing loading only by pressing the LF/FF key. The other options allow automatic feeding after the stated delay time.
SKEW DETECTION	Enable or disable the skew detection for front feeding
SKEW LEVEL	Sets the skew sensor sensitivity. 001 is the most critical while 010 is the least. If a skew error is detected the single sheet will be automatically ejected.

Table 5-2 Description of options

Restoring Factory Printer Settings

You can restore to the factory printer settings without having to work through the Setup Menu System to reset the menus.

To restore to the factory settings:

1. Make sure that the printer is **ONLINE**
2. Press and hold down the **ONLINE** and **COPY** keys on the control panel for 3 seconds.

The LEDs of the **POWER** and **ONLINE** on the control panel flash 3 times respectively at the same time and the printer makes a beep to confirm that the printer's factory settings have been restored.

3. Release the keys and switch the printer off and on again.

After these steps, the printer's factory settings work.

Using the Self Test Functions

Slide Pattern Printing Test

One page printing of ASCII slide pattern is performed by turning power on, while pressing the **LF/FF** key.

Continuous printing of ASCII slide pattern is performed by turning power on, while pressing the **ON- LINE** and **PARK/LOAD** keys.

```
ASCII TEST MODE
Version: 380V X.X 20XX/XX/XX
!"#$%&'()*+,-./0123456789:;<=>?@ABCDEFGHIJKLMNQRSTUUVWXYZ[\]^_`abcdefghijklmnop
!"#$%&'()*+,-./0123456789:;<=>?@ABCDEFGHIJKLMNQRSTUUVWXYZ[\]^_`abcdefghijklmnop
!"#$%&'()*+,-./0123456789:;<=>?@ABCDEFGHIJKLMNQRSTUUVWXYZ[\]^_`abcdefghijklmnop
```

Figure 5-4 The former of English self-test

Maintenance Printing Test (H pattern)

One page printing of H pattern is performed by turning power on, while pressing the **ONLINE** and **LF/FF** keys.

Continuous printing of H pattern is performed by turning power on, while pressing the **COPY** key.

Appendix A

Maintenance and Fault Finding

Introduction

Your printer requires very little routine maintenance. In fact, the best maintenance for the printer is preventative. If you have followed the suggestions for locating it in an area free of excessive dust and heat it will give you a long and trouble-free performance.

Periodic cleaning, replacement of the ribbon, replacement of an occasional blown fuse and, after a very long time, replacement of the print head are about the only maintenance tasks you'll need to carry out. We'll cover these items in this chapter. However, before carrying out any of these tasks make sure that the printer has been switched off.

Cleaning dirt and dust are the biggest enemies. The print head cover will keep most dirt from the printer mechanism, but occasional cleaning to remove paper particles is a good idea.

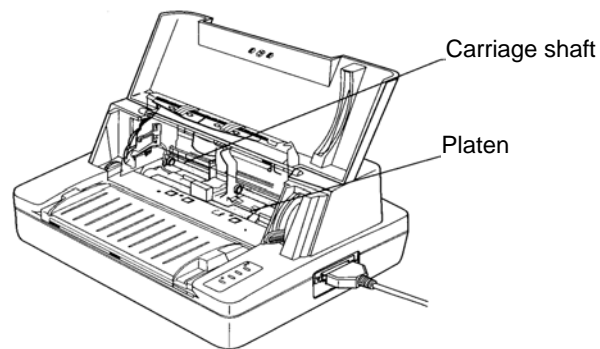

Figure A-1

Cleaning the Cabinet

Wipe soiled parts of the printer with a clean dry cloth. Remove bits of paper, etc., using tweezers.

NOTE

When cleaning, be careful not to scratch the equipment or to bend parts, etc.

Cleaning the Carriage Shaft

The carriage shaft is coated with oil, which attracts dust, etc. wipe solid parts with a soft cloth to clean them.

NOTE

Over-application of oil may cause a build up of dust and dirt with resulting printer failure.

Cleaning the platen

Clean the platen with a soft cloth.

Intervals and Materials for Cleaning

Clean inside the printer in accordance with the following:

NOTE	
Intervals cleaning:	Every 6 months or 300 hours of operation. (Whichever comes first)
Materials:	Dry cloth (gauze or soft cloth)

Ribbon Cartridge The inked ribbon in the cartridge is a continuous loop and will print several million characters before needing replacement. When printed characters begin to appear feint it is time to replace the ribbon cartridge.

Replacing the ribbon is a simple matter of taking out the old cartridge and replacing it with a new one. Before removing the old cartridge always turn off the power and allow the print head to cool, as it can be extremely hot. Then slide the print head to the left edge to avoid damage to the print head cable. See the ribbon installation section in Chapter 2 for details.

Problems And Solutions

The following are some of the common problems, which you may encounter when using the printer. By implementing the solutions suggested, you should be able to resolve them.

Printer is “Dead” No Light, No Action Make sure that it is plugged in, check both ends of the power cable. Make sure the power switch is turned on. Test the socket with another appliance to make sure it is working, check the fuse in the plug attached to the power cable. Take your printer to your dealer to be serviced.

Printer Won’t Work Be sure that the printer cable is plugged into both the printer and the computer. Make sure that there is paper inserted and the **ONLINE** LED is on.

Printing is Feint Be sure that the ribbon cartridge is installed correctly. It must be fitted securely into place and the ribbon must pass between the print head and the ribbon mark. Adjust the gap adjust lever (move it upward). Replace the ribbon. Replace the print head.

Printing is Smudged The ribbon is in front of the ribbon mask. Remove it and then insert it correctly. Adjust the gap adjust lever (move it downward).

Poor Dot Positioning If poor dot positioning occurs, the horizontal dot alignment has to be performed by an authorized technician.

Characters On The Screen Don't Match The Printed Characters Many graphics characters and special symbols are produced by different ASCII codes on each make of computer and printer. Compare the character set charts in your computer manual with the printer character sets.

You Selected A Printer Driver In Your Application Program But The Codes Don't Do The Right Thing (Or Anything) On The Printer Contact your software manufacture to check if a driver for your printer is available.

The Paper Jams Frequently When Using Continuous Forms Make sure that the incoming and outgoing paper is straight. Be sure that the incoming paper is not sticking.

The Paper Jams When Doing Reverse Paper Feeds Be sure that the lid is shut correctly. Don't tear off continuous forms while you are printing. With wider paper the right edge of the first page may not be flat against the platen. Increase the top margin or advance to the second sheet before you start printing.

Error LED on the Control Panel

In the case of printer error, the printer enters offline state and indicates an alarm by blinking the LED's as shown below.

LED	Error	Cause	Remedy
The POWER LED blinks and the ONLINE LED is off.	Paper empty or paper jam	The printer is out of paper or jamming	Load paper or remove the jammed paper
The POWER and the ONLINE LED blink simultaneously quickly.	Paper slant	The inserted cut sheet paper is slanting	Re-insert the cut sheet paper correctly
The POWER and the ONLINE LED blink alternately quickly.	Home position error	The print head carrier mechanism is out of position	Turn off the power and turn it on again. If an error still occurs, clean and lubricate the carriage shaft
The POWER and the ONLINE LED blink alternately slowly.	Select lever error	The select lever is changed after loading paper	Return the select lever to the correct position
The POWER LED is on and the ONLINE LED blinks.	Head overheating	The print head is overheated	Automatically cleared when print head temperature decreases

Appendix B

Specifications

General

Type	24-Pin Flatbed Dot Matrix Impact Printer	
Fonts	1 DP (Draft) 7 LQ (ROMAN, SANSERIF, COURIER, PRESTIGE, SCRIPT, OCRA, OCRB)	
Emulation	Epson ESC/P2	
Memory	256K bytes (*Input buffer: 132K bytes)	
Interface	Parallel Interface: Centronics (IEEE 1284 NIBBLE mode Compatible) USB Interface: USB 2.0 Full-Speed	
Ribbon	Color:	Black
	Life:	3 million characters (draft mode)
Power requirements	Rated voltage AC 220 V Input voltage range AC 198 to 264 V Rated frequency range 50 to 60 Hz Input frequency range 49.5 to 60.5 Hz	
Environmental conditions	Operating temperature	5~35°C
	Operating humidity	10%~80%RH(No condensation)
	Storage temperature	-20~55°C
	Storage humidity	5%~85%RH(No condensation)
MTBF	5,000 hours, except the print head	
MTTR	Less than 20 minutes	
Weight (unpacking)	Approx. 6.3 Kg	
Physical dimensions (Without front table)	417×325×205mm (width/depth/height)	

Print Head

Print head wire diameter	0.2mm
Wire pitch	1/180 inch
Print head life	200 million strokes/wire

Mechanism

Print speed	Mode	10 CPI	12 CPI	15 CPI
	DP	250CPS	300 CPS	375 CPS
		120 DPI	120 DPI	120 DPI
	LQ	83 CPS	100 CPS	125CPS
		360 DPI	360 DPI	360 DPI
Paper feed Speed	Paper slew speed (Continuous feed): 5.0 IPS (inches per second)			
	Pitch: Variable in 1/360 inch increments			
Number of columns	80 columns (10 CPI)			
Copy capability	Normal: Original + 2 copies			
	Copy mode 1: Original + 2~4 copies			
	Copy mode 2: Original + 6 copies—1 pass-printing			
	Copy mode 3: Original + 6 copies—2 pass-printing			
Head gap adjustment	Manual			
Resolution	360 x 360 DPI maximum			

Paper

Paper size	Cut sheet	Width: 89 to 257 mm Length: 56 to 462 mm
	Fanfold	Width: 101 to 257 mm
Paper thickness	Cut sheet: 0.06~0.12mm	
	Fanfold paper: 0.06~0.12 mm – Single sheet 0.06~0.45 mm – Total	
Paper type	Cut sheet, tractor paper, label, check, post card, and envelope	
Paper feed mechanism	Friction: manual insertion from the front table, ejection to the front	
	Tractor: insert from the rear, eject to the front, with tear-off and paper park functions	

Print mode specifications

Print mode		Multipart mode	Dot Spacing (V×H inches)	Max No. of Columns	Character Structure (V×H)	Printing Speed (cps)
LQ (Normal Speed)	10dpi	Normal	1/180×1/360	80	24×18	83
		Dark 1				66
		Dark 2				53
		Dark 3				26
	12dpi	Normal	1/180×1/360	96	24×18	100
		Dark 1				80
		Dark 2				64
		Dark 3				32
	15dpi	Normal	1/180×1/360	120	16×12	125
		Dark 1				100
		Dark 2				80
		Dark 3				40
Draft (High Speed)	10dpi	Normal	1/180×1/120	80	24×9	250
		Dark 1				200
		Dark 2				160
		Dark 3				80
	12dpi	Normal	1/180×1/120	96	24×7	300
		Dark 1				240
		Dark 2				192
		Dark 3				89
	15dpi	Normal	1/180×1/120	120	16×7	375
		Dark 1				300
		Dark 2				240
		Dark 3				120

Graphic Print Specifications

Graphic type		Horizontal dot pitch	Multipart mode	Print speed (inch/second)
Density	Pins			
120dpi	24	1/240 inch	Normal、Dark 1	9.9
			Dark 2	8
			Dark 3	3.9
180dpi	24	1/360 inch	Normal、Dark 1	6.6
			Dark 2	5.3
			Dark 3	2.6
360dpi	24	1/360 inch	Normal、Dark 1	6.6
			Dark 2	5.3
			Dark 3	2.6

Parallel Interface

Signal level

Input High level: 2 to 5V, Low level: 0 to 0.8V

Output High level: 2.4 to 5V, Low level: 0 to 0.4V

Connector Pin Assignments

Signal Pin No.	Return Line Pin No.	Signal Name	Signal Direction
1	19	/STROBE	Printer ← Host
2~9	20~27	DATA	Printer ← Host
10	28	/ACK	Printer → Host
11	29	BUSY	Printer → Host
12	30	PE	Printer → Host
13	—	SELECT	Printer → Host
14	—	/AUTO FEED	Printer ← Host
15	—	NC	NC
16	—	SIGNAL GND	Printer↔ Host
17	—	CHASSIS GND	Printer↔ Host
18	—	+5V	Printer → Host
31	—	/PRIME	Printer← Host
32	—	/ERROR	Printer → Host
33	—	SIGNAL GND	Printer ↔ Host
34	—	NC	Printer → Host
35	—	PULLED UP 5V	Printer → Host
36	—	/SELECT IN	Printer← Host

USB Interface

USB 2.0 Full-Speed.

The following table provides the standardized contact terminating assignments by number and electrical value for Series “A” and Series “B” connectors.

Contact Number	Signal Name	Typical Wiring Assignment
1	VBUS	Red
2	D-	White
3	D+	Green
4	GND	Black
Shell	Shield	Wire

Command Code Summary

Epson Emulation

Name	Code (Symbol)	Code (Hex.)	Code (Dec.)
Print and Line Feed Execution			
Carriage Return	CR	0D _h	13 _d
Line Feed	LF	0A _h	10 _d
n/180” Line Feed	ESC J	1B _h 4A _h	27 _d 74 _d
n/180” Reverse Line Feed	ESC j	1B _h 6A _h	27 _d 106 _d
Format Control			
Set 1/8” Line Spacing	ESC 0	1B _h 30 _h	27 _d 48 _d
Set 1/6” Line Spacing	ESC 2	1B _h 32 _h	27 _d 50 _d
Set n/180” Line Spacing	ESC 3	1B _h 32 _h	27 _d 51 _d
Set n/60” Line Spacing	ESC A	1B _h 41 _h	27 _d 65 _d
Set n/360” Line Spacing	ESC +	1B _h 2B _h	27 _d 43 _d
Form Feed	FF	0C _h	12 _d
Set Form Length in Lines	ESC C	1B _h 43 _h	27 _d 67 _d
Set Form Length in Inches	ESC C NUL	1B _h 43 _h 00 _h	27 _d 67 _d 0 _d
Set Form Length in Defined Unit	ESC (C	1B _h 28 _h 43 _h	27 _d 40 _d 67 _d
Select Skip-Over-Perforation	ESC N n	1B _h 4E _h	27 _d 78 _d
Cancel Skip-Over-Perforation	ESC O	1B _h 4F _h	27 _d 79 _d
Vertical Tab	VT	0B _h	11 _d
Set Vertical Tab Positions	ESC B	1B _h 42 _h	27 _d 66 _d
Select a VFU Channel	ESC /	1B _h 2F _h	27 _d 47 _d
Select VFU Positions	ESC b	1B _h 62 _h	27 _d 98 _d
Set right Margin	ESC Q	1B _h 51 _h	27 _d 81 _d

Name	Code (Symbol)	Code (Hex.)	Code (Dec.)
Set Left Margin	ESC I	1B _h 6C _h	27 _d 108 _d
Horizontal Tab	HT	09 _h	9 _d
Set Horizontal Tab Positions	ESC D	1B _h 44 _h	27 _d 68 _d
Set Character Space	ESC SP	1B _h 20 _h	27 _d 32 _d
Set Absolute Horizontal Tab	ESC \$	1B _h 24 _h	27 _d 36 _d
Set Relative Dot Position	ESC \	1B _h 5C _h	27 _d 92 _d
Define Unit	ESC (U	1B _h 28 _h 55 _h	27 _d 40 _d 85 _d
Set Absolute Vertical Print Position	ESC (V	1B _h 28 _h 56 _h	27 _d 40 _d 86 _d
Set Relative Vertical Print Position	ESC (v	1B _h 28 _h 76 _h	27 _d 40 _d 118 _d
Set Form Format	ESC (c	1B _h 28 _h 63 _h	27 _d 40 _d 99 _d
Set Horizontal Motion Index (HM)	ESC c	1B _h 63 _h	27 _d 99 _d
Print Mode			
Select Print Quality	ESC x	1B _h 78 _h	27 _d 120 _d
Select ELITE Width Mode (12CPI)	ESC M	1B _h 4D _h	27 _d 77 _d
Select PICA Width Mode (10CPI)	ESC P	1B _h 50 _h	27 _d 80 _d
Select 15CPI Mode	ESC g	1B _h 67 _h	27 _d 103 _d
Select/Cancel Proportional Mode	ESC p	1B _h 70 _h	27 _d 112 _d
Select Double Width Mode (one line)	SO	0E _h	14 _d
Cancel Double Width Mode (one line)	DC4	14 _h	20 _d
Select/Cancel Double Width Mode	ESC W	1B _h 57 _h	27 _d 87 _d
Select Compressed Mode	SI	0F _h	15 _d
Cancel Compressed Mode	DC2	12 _h	18 _d
Select Emphasized Mode	ESC E	1B _h 45 _h	27 _d 69 _d
Cancel Emphasized Mode	ESC F	1B _h 46 _h	27 _d 70 _d
Select Double Strike Mode	ESC G	1B _h 47 _h	27 _d 71 _d
Cancel Double Strike Mode	ESC H	1B _h 48 _h	27 _d 72 _d
Select Italic Mode	ESC 4	1B _h 34 _h	27 _d 52 _d
Cancel Italic Mode	ESC 5	1B _h 35 _h	27 _d 53 _d
Select/Cancel Underline Mode	ESC - n	1B _h 2D _h	27 _d 45 _d
Select Superscript/Subscript Mode	ESC S n	1B _h 53 _h	27 _d 83 _d
Cancel Superscript/Subscript Mode	ESC T	1B _h 54 _h	27 _d 84 _d
Select Print Mode	ESC ! n	1B _h 21 _h	27 _d 33 _d
Select/Cancel Double Height Mode	ESC w n	1B _h 77 _h	27 _d 119 _d
Select/Cancel Quiet Print Mode	ESC s n	1B _h 73 _h	27 _d 115 _d
Select Justification Mode	ESC a n	1B _h 61 _h	27 _d 97 _d
Select Character Style	ESC q n	1B _h 71 _h	27 _d 113 _d
Define and Apply a Style of Scoring	ESC (-	1B _h 28 _h 2D _h	27 _d 40 _d 45 _d
Print Data as Characters	ESC (^	1B _h 28 _h 5E _h	27 _d 40 _d 94 _d
Character Set			
Select International Character Set	ESC R	1B _h 52 _h	27 _d 82 _d
Select Font Style	ESC k	1B _h 6B _h	27 _d 107 _d

Name	Code (Symbol)	Code (Hex.)	Code (Dec.)
Select Character Table	ESC t n	1B _h 74 _h	27 _d 116 _d
Enable Character Set 2	ESC 6	1B _h 36 _h	27 _d 54 _d
Cancel command ESC 6	ESC 7	1B _h 37 _h	27 _d 55 _d
Assign Character Table	ESC (t	1B _h 28 _h 74 _h	27 _d 40 _d 116 _d
Download Character			
Select/Deselect User-Defined Set	ESC % n	1B _h 25 _h	27 _d 37 _d
Define Downloaded Characters	ESC &	1B _h 26 _h	27 _d 38 _d
Copy ROM Characters Set into RAM	ESC :	1B _h 3A _h	27 _d 58 _d
Bit-Image			
Select Single-Density Graphics Mode	ESC K	1B _h 4B _h	27 _d 75 _d
Select Double-Density Graphics Mode	ESC L	1B _h 4C _h	27 _d 76 _d
Select High-speed, Double-Density	ESC Y	1B _h 59 _h	27 _d 89 _d
Select Quadruple-Density	ESC Z	1B _h 5A _h	27 _d 90 _d
Graphics Mode			
Select Graphics Mode	ESC *	1B _h 2A _h	27 _d 42 _d
Reassign Graphics Mode	ESC ?	1B _h 3F _h	27 _d 63 _d
Select Graphics Mode	ESC (G	1B _h 28 _h 47 _h	27 _d 40 _d 71 _d
Print Raster Graphics	ESC .	1B _h 2E _h	27 _d 46 _d
Input Data Control			
Cancel Line	CAN	18 _h	24 _d
Delete Character	DEL	7F _h	127 _d
Select Printer	DC1	11 _h	17 _d
Deselect Printer	DC3	13 _h	19 _d
Cancel MSB Control Sequence	ESC #	1B _h 23 _h	27 _d 35 _d
Set MSB to 1	ESC >	1B _h 3E _h	27 _d 62 _d
Reset MSB to 0	ESC =	1B _h 3D _h	27 _d 61 _d
Miscellaneous			
Null	NUL	00 _h	0 _d
Beeper	BEL	07 _h	7 _d
Backspace	BS	08 _h	8 _d
Initialize Printer	ESC @	1B _h 40 _h	27 _d 64 _d
Select Unidirectional Mode (on line)	ESC <	1B _h 3C _h	27 _d 60 _d
Select Print Direction	ESC U n	1B _h 55 _h	27 _d 85 _d

Select Code Pages

Format	ESC (t n1 n2 d1 d2 d3 (n1=3, n2=0, d1=0,1,2,3))		
Code No.	d2	d3 (HEX)	Name
437	1	0	U.S.A.
437GR	1	10	GRK 437
858	3	0	MULTI
851GR	4	0	GRK 851
857	5	0	TURKEY
855	6	0	CYRILLIC
860	7	0	PORTUGAL
863	8	0	CANADA
865	9	0	NORWAY
852	0A	0	EAST EUROPE
864	0D	0	ARAB NLS
866	0E	0	RUSSIAN
1253	0F	0	GRK 1253
861	18	0	ICELAND
1252	19	0	WIN LAT1
1250	1A	0	WIN LAT2
Hungarian	1B	0	HUNGARY
895	1C	0	KAMENICKY
Bulgaria	1D	0	BULGARIA
ISO-8859-15	1D	0F	ISO LTN9
Mazovia	1E	0	MAZOVIA
ISO-8859-7	1F	0	GRK 8859-7
ARAB EXT	20	0	ARAB EXT
ISO-8859-1	21	0	ISO LTN1
ISO-8850-2	22	0	ISO LTN2
KBL	23	0	KBL
ISO-8859-13	24	0	ISO LTN7
ISO-8859-9	2C	0	ISO-8859-9 TURKEY

Unique Commands

The following commands are in both emulations

Park/Load Paper — ESC ~ g n

Format: 1B_h 7E_h 67_h n (loads : n = 1_d or 49_d, feeds : n = 0_d or 48_d)

Loads fanfold paper when n is set to 1, or feeds fanfold paper to the parked position when n is set to 0.

When the fanfold paper is at the parked position, this command with n set to 0 is ignored.

Set Top Margin — ESC ~ V n

Format: 1B_h 7E_h 56_h n (0_d ≤ n ≤ 120_d)

Sets the distance between the paper end and the print start position to n/60 inch.

Set/Reset Slashed Zero — ESC ~ 4 n

Format: 1B_h 7E_h 34_h n (slashed : n = 1_d or 49_d, unslashed : n = 0_d or 48_d)

Prints slashed zero character (0) or unslashed zero character (0).

Select Emulation — ESC ~ 5 n

Format: 1B_h 7E_h 35_h n (IBM : n = 1_d or 49_d, Epson : n = 0_d or 48_d)

Selects emulation Epson or IBM.

Bar Code Printing — ESC } n R k m₁ m₂ v₁ v₂ c data

Format: 1B_h 7D_h n 52_h k m₁ m₂ v₁ v₂ c data

Selects barcode printing. n indicates the number of bytes contained in the command except ESC }. This includes n itself and the terminating ' R ' character. If any error is detected in the command, the n bytes of data following the ESC } will be discarded. See the descriptions of the different barcode types for additional information.

k selects the type of barcode to be printed according to the table below. Any value other than those shown cause the command to be ignored and the n bytes following ESC } to be discarded from the buffer.

k	: type
B1 _h	: NW-7
B2 _h	: EAN-13
B3 _h	: EAN-8
B4 _h	: Code 39
B5 _h	: Industrial 2 of 5
B6 _h	: Interleaved 2 of 5
BE _h	: Code 128 B
BF _h	: Code 128 C

Reference Section 2

1. When the NW-7 barcode type is selected, no check digit is added, regardless of the setting of bit 0.

If the barcode specified would exceed the right margin, it will not be printed and the n bytes following ESC } will be discarded from the buffer.

If the barcode specified would exceed the bottom margin, only that portion which will fit above the margin will be printed. The printer can keep track of up to four barcodes simultaneously. If four barcodes are currently being printed and have not been completed, a new barcode command will be ignored, and the n bytes following ESC } will be discarded from the buffer. If the printer is set to off-line while printing a barcode, and paper movement or pitch change is performed from the front panel, the unfinished portion of the barcode will not be printed when the printer is placed on-line again. Barcodes are always printed unidirectionally, in two passes.

Example (Basic Format):

```
100 LPRINT " ABCDE ";
110 LPRINT CHR$(27)"}" CHR$(17) " R";
120 LPRINT CHR$(&HB1)CHR$(0)CHR$(24)CHR$(2)CHR$(0)CHR$(&H10)"123456789";
130 LPRINT " FGHIJ"
140 LPRINT
150 LPRINT " OPQRS";
160 LPRINT CHR$(27)"}" CHR$(17) " R";
170 LPRINT CHR$(&HB1)CHR$(0)CHR$(24)CHR$(2)CHR$(0)CHR$(&H90)"123456789";
180 LPRINT " TUVWX "
190 LPRINT
```

This example first prints a line (lines 100-130) containing an NW-7 barcode [CHR\$(&HB1)], with a narrow element width of 3 dot columns [(CHR\$(0) x 256) + CHR\$(24)] which extends for 512/1440 inch [(CHR\$(2) x 256) + CHR\$(0)] or about 3/8 inch. The text printed by this line prints ABCDE, the first pass of the barcode, then FGHIJ. The next print line (140) contains no text, but since the barcode is not completely printed, the printer prints its next pass.

The next print line (150-180) contains text that must print on either side of the barcode, directly underneath ABCDE and FGHIJ. TUVWX is positioned properly by resending the barcode command, but with the control byte changed to 90_h from 10_h. This causes the printer to skip horizontally a distance equal to the width of the specified barcode. This form of the command does not cause any printing by itself, but since there is still more of the original barcode left to print, it prints in the space left by this command. The last line (190) contains no new text, except the last pass of the original barcode prints.

Barcode Details

Barcode data is printed on the page according to the diagram below:

s	d	d	d	...	d	c	s
c	1	2	3	...	k	d	c

sc: start/stop code (optional depending on barcode type)
 d₁...d_k: barcode data
 cd: check digit (optional depending on barcode type)

The start/stop code and check digit may or may not be present, depending on the settings in element *c*, or the requirements of the particular barcode type being printed.

NW-7

The barcode data can consist of 1 to 34 characters, so the valid range for *n* is from 9 to 42. If *n* < 9 or *n* > 42, the command will be ignored and the *n* bytes following **ESC }** will be discarded from the buffer.

Legal DATA characters: 0 - 9, +, -, \, ., /, :

Legal START/STOP characters: A, B, C, D, E, N, T, *

If any illegal characters are encountered, the command will be ignored and the *n* bytes following **ESC }** will be discarded from the buffer. No check digit is defined for this type of barcode, so a check digit will not be printed, regardless of the setting of bit 0 of element *c* of the command.

CODE 39

The barcode data can consist of 1 to 32 characters if no check digit is selected (bit 0 of element *c*), or 1 to 31 characters if a check digit is selected. Therefore the valid range for *n* is from 9 to 40 with no check digit, or 9 to 39 with a check digit. If *n* < 9 or *n* > the maximum value, the command will be ignored and the *n* bytes following **ESC }** will be discarded from the buffer.

Legal DATA characters: 0 - 9, A - Z, +, -, %, \$, ., <<space>>

The **START/STOP** character “*” will automatically be added to the beginning and the end of the data. If printing of a human-readable representation is specified (bit 1 of *c*), the **START/STOP** characters will also be printed with the data. If any illegal characters are encountered, the command will be ignored and the *n* bytes following **ESC }** will be discarded from the buffer.

How to calculate the check digit:

1. Using the table of the next page, add up the values of all the characters in the barcode data.
2. Divide the result by 43. The check digit is the one corresponding to the value of the remainder from the division.

For example:

assume barcode data of **CLABK 13001**. The sum of the value(s) of the characters is 12 + 21 + 10 + 11 + 20 + 1 + 3 + 0 + 0 + 1 = 79. 79/43 = 1 with a remainder of 36. The check digit is the character with the value of 36, or “-”.

Reference Section 2

Code 39 Character Values

Character	Value	Character	Value	Character	Value	Character	Value	Character	Value
0	0	A	10	K	20	U	30	/	40
1	1	B	11	L	21	V	31	+	41
2	2	C	12	M	22	W	32	%	42
3	3	D	13	N	23	X	33		
4	4	E	14	O	24	Y	34		
5	5	F	15	P	25	Z	35		
6	6	G	16	Q	26	-	36		
7	7	H	17	R	27	.	37		
8	8	I	18	S	28	<<space>>	38		
9	9	J	19	T	29	\$	39		

INDUSTRIAL 2 OF 5

The barcode data can consist of 1 to 32 characters if no check digit is selected (bit 0 of element c), or 1 to 31 characters if a check digit is selected. Therefore the valid range for n is from 9 to 40 with no check digit, or 9 to 39 with a check digit. If $n < 9$ or $n >$ the maximum value, the command will be ignored and the n bytes following ESC } will be discarded from the buffer.

Legal DATA characters: 0 - 9

If the barcode data consists of an odd number of characters, the printer will add a " 0" to the beginning of the barcode to make an even number of characters.

The **START/STOP** code will automatically be added to the beginning and end of the data. If printing of a human-readable representation is specified (bit 1 of c), the **START/STOP** codes will not be printed with the data, since it is not a printable character. If any illegal characters are encountered, the command will be ignored and the n bytes following ESC } will be discarded from the buffer.

How to calculate the check digit :

1. Assume that barcode data is $A_1 A_2 A_3 A_4 A_5 A_6 A_7$.
2. If necessary, put zero (0) before first data field (A_1) because the final data must be even field. In the above example, the zero (0) must be put before first data field.
Then modified data becomes $A_0 A_1 A_2 A_3 A_4 A_5 A_6 A_7$. ($A_0 = 0$)
3. Add up even fields data ($A_{EVSUM1} = A_1 + A_3 + A_5 + A_7$).
4. Multiply the A_{EVSUM1} by 3 ($A_{EVSUM3} = A_{EVSUM1} * 3$).
5. Add up odd fields data ($A_{ODSUM} = A_0 + A_2 + A_4 + A_6$).
6. Add up the A_{EVSUM3} to A_{ODSUM} ($A_{EOSUM} = A_{EVSUM3} + A_{ODSUM}$).
7. Find B_0 under following conditions.
The conditions are as follows :
 $B_1 = B_0 * 10$, $B_1 \geq A_{EOSUM}$, B_1 and B_0 must be integer, and the B_1 must be nearest the A_{EOSUM} .
8. The Check Digit (CD) is difference between B_1 and A_{EOSUM} ($CD = B_1 - A_{EOSUM}$).

For example, assume barcode data of 130573429. Since the number of data items is odd, the program adds a zero to the beginning, so that the barcode will be made from this data: 0130573429.

The sum of the even items is $1 + 0 + 7 + 4 + 9 = 21$. $21 \times 3 = 63$. The sum of the odd items is $0 + 3 + 5 + 3 + 2 = 13$. The sum of the results is $63 + 13 = 76$. The nearest multiple of 10 that is greater than 76 is 80. The check digit is $80 - 76 = 4$.

INTERLEAVED 2 OF 5

See industrial 2 of 5 for allowable numbers of characters, legal characters, and calculation of check digit.

EAN-13

The barcode data consists of 12 characters. Therefore the maximum possible value for n is 20. If n is greater than 20, the command will be ignored and the n bytes following ESC } will be discarded from the buffer.

Legal DATA characters : 0 - 9

If any illegal characters are encountered, the command will be ignored and the n bytes following ESC } will be discarded from the buffer. The construction of the data is as follows:

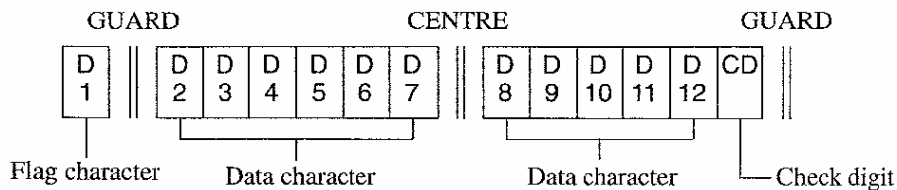

The flag character can be printed. But the flag character will not be printed if the barcode is printed from the left margin.

How to calculate the check digit :

1. Assume that barcode data is $A_1 A_2 A_3 A_4 A_5 A_6 A_7 A_8 A_9 A_{10} A_{11} A_{12}$.
2. Add up even fields data ($A_{EVSUM1} = A_2 + A_4 + A_6 + A_8 + A_{10} + A_{12}$).
3. Multiply the A_{EVSUM1} by 3 ($A_{EVSUM3} = A_{EVSUM1} * 3$).
4. Add up odd fields data ($A_{ODSUM} = A_1 + A_3 + A_5 + A_7 + A_9 + A_{11}$).
5. Add up the A_{EVSUM3} to A_{ODSUM} ($A_{EOSUM} = A_{EVSUM3} + A_{ODSUM}$).
6. Find B_0 under following conditions.
The conditions are as follows :
 $B_1 = B_0 * 10$, $B_1 \geq A_{EOSUM}$, B_1 and B_0 must be integer, and the B_1 must be nearest the A_{EOSUM} .
7. The Check Digit (CD) is different between B_1 and A_{EOSUM} ($CD = B_1 - A_{EOSUM}$).

EAN-8

The barcode data consists of 7 characters. Therefore the maximum possible value for n is 15. If n is greater than 15, the command doesn't operate normally.

Legal DATA characters : 0 - 9

If any illegal characters are encountered, the command will be ignored and the n bytes following ESC } will be discarded from the buffer. The construction of the data is as follows:

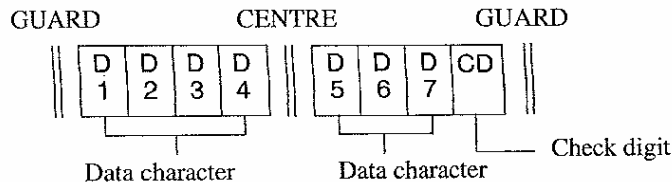

Reference Section 2

How to calculate the check digit :

1. Assume that barcode data is $A_1 A_2 A_3 A_4 A_5 A_6 A_7$.
2. Put zero (0) before first data field (A_1) because the final data must be even field.
Then modified data becomes $A_0 A_1 A_2 A_3 A_4 A_5 A_6 A_7$. ($A_0 = 0$)
3. Add up even fields data ($A_{EVSUM1} = A_1 + A_3 + A_5 + A_7$).
4. Multiply the A_{EVSUM1} by 3 ($A_{EVSUM3} = A_{EVSUM1} * 3$).
5. Add up odd fields data ($A_{ODSUM} = A_0 + A_2 + A_4 + A_6$).
6. Add up the A_{EVSUM3} to A_{ODSUM} ($A_{EOSUM} = A_{EVSUM3} + A_{ODSUM}$).
7. Find B_0 under the following conditions. The conditions are as follows :
 $B_1 = B_0 * 10$, $B_1 \geq A_{EOSUM}$, B_1 and B_0 must be integer, and the B_1 must be nearest the A_{EOSUM} .
8. The Check Digit (CD) is difference between B_1 and A_{EOSUM} ($CD = B_1 - A_{EOSUM}$).

CODE 128 B

Legal DATA characters : ASCII characters 20_h to $7F_h$.

(Value 0 to 95 in the Code 128 Character Value table on page E-15)

Value 104 is added automatically as the **START** character, and the **STOP** code is added automatically as the **STOP** character.

The check character is added automatically, regardless of the value of c .

The step of calculations are as follows:

1. Obtain the value for each data character except for the **STOP** code by referring to the table on page E-15.
2. Multiply the **START** code by 1.
3. Multiply the first character by 1.
4. Multiply the second character by 2, the third character by 3, the fourth character by 4, and so forth.
5. Sum up all the values obtained at steps 2) to 4) above.
6. Divide the result of step 5) by 103 and obtain the remainder.
7. Obtain the character corresponding to the remainder which is the check digit to be applied.

CODE 128 C

Legal DATA characters : ASCII characters 30_h to 39_h .

(Value 0 to 99 in the Code 128 Character Values table on page E-15).

Value 105 is added automatically as the **START** character, and the **STOP** code is added automatically as the **STOP** character.

The check character is added automatically, regardless of the value of c , calculated in the same way as for **CODE 128 B**.

To adjust the columns, when the total number of characters is even, " 0" is added before the first character.

Exampe: when " 0123456 " is sent from the host computer

START	00	12	34	56	Check character	STOP
-------	----	----	----	----	-----------------	------

Reference Section 2

Code 128 Character Values

Character CODE B	Character CODE C	Value	Character CODE B	Character CODE C	Value	Character CODE B	Character CODE C	Value
SP	00	0	D	36	36	h	72	72
!	01	1	E	37	37	i	73	73
"	02	2	F	38	38	j	74	74
#	03	3	G	39	39	k	75	75
\$	04	4	H	40	40	l	76	76
%	05	5	I	41	41	m	77	77
&	06	6	J	42	42	n	78	78
'	07	7	K	43	43	o	79	79
(08	8	L	44	44	p	80	80
)	09	9	M	45	45	q	81	81
*	10	10	N	46	46	r	82	82
+	11	11	O	47	47	s	83	83
,	12	12	P	48	48	t	84	84
-	13	13	Q	49	49	u	85	85
.	14	14	R	50	50	v	86	86
/	15	15	S	51	51	w	87	87
0	16	16	T	52	52	x	88	88
1	17	17	U	53	53	y	89	89
2	18	18	V	54	54	z	90	90
3	19	19	W	55	55	{	91	91
4	20	20	X	56	56		92	92
5	21	21	Y	57	57	}	93	93
6	22	22	Z	58	58	~	94	94
7	23	23	[59	59	DEL	95	95
8	24	24	\	60	60		96	96
9	25	25]	61	61		97	97
:	26	26		62	62		98	98
;	27	27		63	63		99	99
<	28	28		64	64			100
=	29	29	a	65	65			101
>	30	30	b	66	66			102
?	31	31	c	67	67			103
@	32	32	d	68	68	START		104
A	33	33	e	69	69		START	105
B	34	34	f	70	70	STOP	STOP	106
C	35	35	g	71	71			

This printer complies with the regulation about the maximum noise level in the work place – 3. GPSGV, under which the highest noise level has to be 70 dB (A) or less in accordance with ISO7779.

Maschinenlärminformations-Verordnung - 3. GPSGV, der höchste Schalldruckpegel beträgt 70 dB(A) oder weniger gemäß ISO7779.

This unit complies with Low Voltage Directive 2006/95/EC and the EMC Directive 2004/108/EC.

Dies Gerät entspricht den Bedingungen der Niederspannungs-Vorschrift 2006/95/EC und dem EMVG nach 2004/108/EC.

Company name: SEIKO PRECISION (Europe) GmbH

Address: Hermann-Buck-Weg 9, D-22309 Hamburg , Germany